



EN

DE

ES

FR

IT

NL

PT

Quick Start Guide

*Cell Pro(Add-on Camera)

*Cell Pro Kit(Hub+Camera)

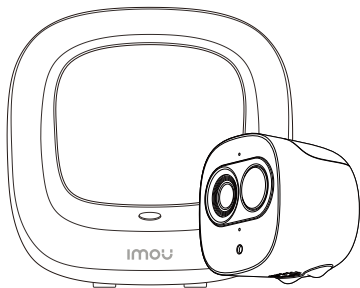

Welcome

Thank you for choosing IMOU.

We are devoted to providing you easy smart home products. If you have problems using the product, please contact our service team before returning your product.

Our service mail: service.global@imoulife.com

Frequently asked questions can be found at imoulife.com/support/help



Package content



Camera x1



Quick Start Guide x1



Power Adapter x1



Bracket x1



Positioning Map x1



Power Cable x1



Screw Package x1



Battery x1



Hub x1

Camera introduction

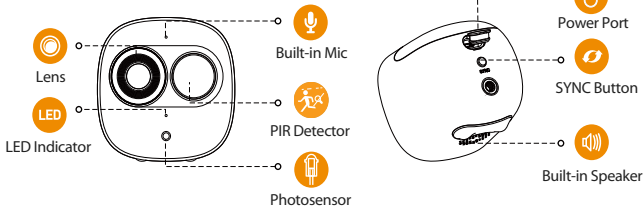

Note: Press the SYNC button to pair with the base station.
Press and hold the SYNC button for 8s to reset the camera.

Installing Battery

EN

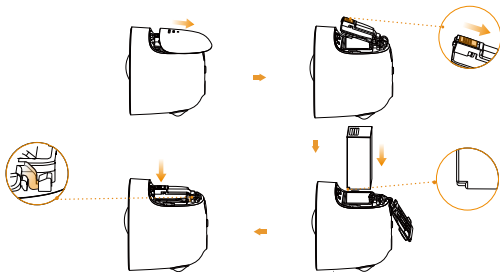

The pattern of the LED indicator is included in the following table.

LED Indicator Status	Device Status
off	<ul style="list-style-type: none">● Sleeping mode● Run out of battery
Green light on	<ul style="list-style-type: none">● Alarm is triggered● Instructed to wake
Green light flashing	<ul style="list-style-type: none">● Reconnecting Wi-Fi
Green light quick flashing	<ul style="list-style-type: none">● Waiting for pairing with the base station
Green light stay on for 10 s, then off	<ul style="list-style-type: none">● Pairing succeeded
Red light stay on for 10 s, then off	<ul style="list-style-type: none">● Pairing timeout
Red light stay on for 1 s, then off	<ul style="list-style-type: none">● Reset completed

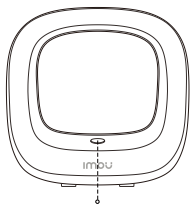

SYNC Button

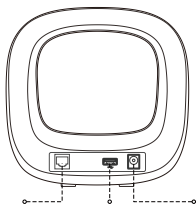

Ethernet Port

USB Port

Power Port

1

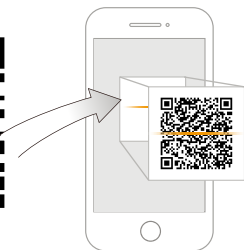

Imou Life

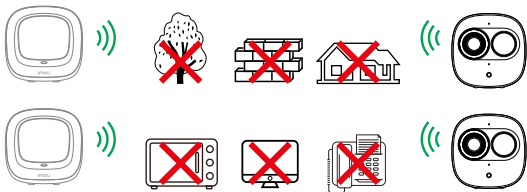

Windows

i Tips

To ensure the best possible wireless performance, please make sure there are no obstacles and electromagnetic interference between the camera and hub.

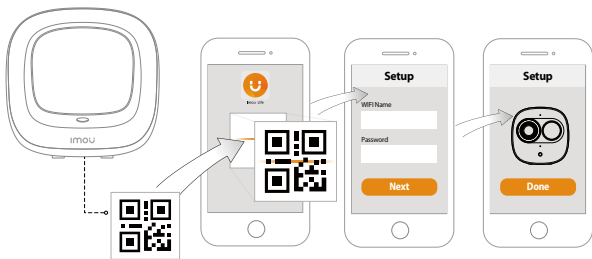
2

3 Pairing with the Hub

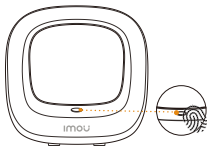

- 1 Press the SYNC button, and then the indicator on the base station flashes with white light.

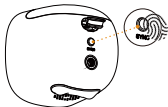

- 2 Press the SYNC button, and then the indicator on the camera flashes with green light.

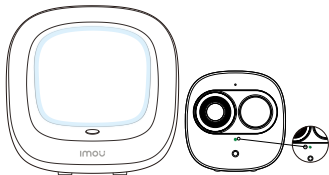

- 3
- The system indicator on the Hub stays on with white light for 10 s, and then off.
 - The indicator on the camera stays on with green light for 10 s, and then off.

Note: You can pair six cameras at most with one Hub, and pair one camera at a time. Keep the distance of the Hub and the camera within 30 cm (12 inches) during pairing.

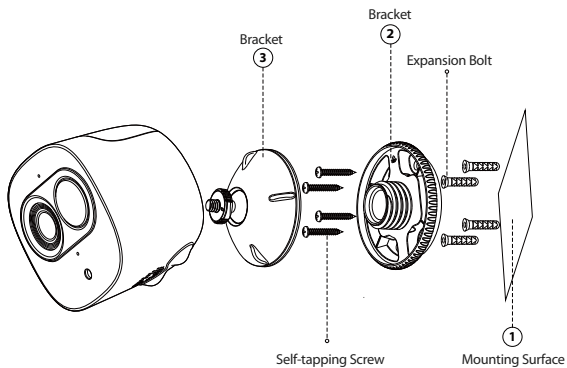

3 Pairing mit dem Hub



Problem	Solution
Cannot set up camera	<ul style="list-style-type: none"> • Ensure your mobile device and the camera are within range of your Wi-Fi router. • Ensure the LED indicator on the camera is flashing green before beginning setup.
The APP says "Failed to configure device network"	<ul style="list-style-type: none"> • Reset your Camera and connect it again. • Some cameras only support 2.4GHz, while some routers have dual band, 2.4G/5G. Make sure you are connecting 2.4GHz only.
The app says "Failed to bind"	<p>The camera is already connected to Wi-Fi, but the router is:</p> <ul style="list-style-type: none"> • Not connected to Internet • Poor network status • The Wi-Fi signal is not stable due to obstacles or electronic interference
No picture / signal	<ul style="list-style-type: none"> • Ensure the LED indicator on the camera is flashing steady green. See 'LED Status' section for details if otherwise. • Ensure the camera is properly connected to power using the included USB power adapter. • Try repositioning the camera, router, or both to improve signal strength.
Picture is not clear	<ul style="list-style-type: none"> • Check the camera lens for dirt, dust, spider webs. Clean the lens with a soft, clean cloth. • Remove the vinyl cover on the camera lens.
No audio	<ul style="list-style-type: none"> • Ensure audio function on camera is turned on. • Ensure audio is turned up on viewing device.
Phone is not reading QR code	<ul style="list-style-type: none"> • Clean the camera lens of your Smartphone • Ensure that there is enough light on the QR code • Don't hold the QR code too close to the camera

Kurzanleitung

*Cell Pro(Add-on Camera)

*Cell Pro Kit(Hub+Camera)

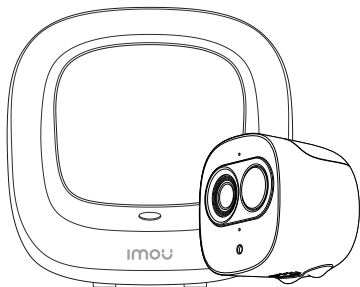

Willkommen

Vielen Dank, dass Sie sich für IMOU entschieden haben. Wir sind bestrebt, einfachere Produkte für das intelligente Heim anzubieten. Wenn Sie Probleme bei der Verwendung des Produkts haben, wenden Sie sich bitte an unser Serviceteam.

Unsere Service-Mail lautet: service.global@imoulife.com

Häufig gestellte Fragen finden Sie unter imoulife.com/support/help



Packungsinhalt

DE



Kamera x1



Kurzanleitung x1



Netzteil x1



Halterung x1



Bohrlochschaablone x1



Stromkabel x1



Befestigungsmaterial x1



Akku x1



Hub x1

Einführung in die Kamera

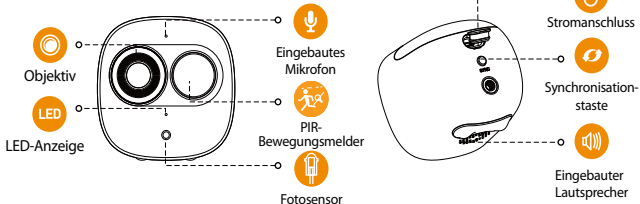

Hinweis: Drücken Sie die Synchronisationstaste SYNC, um eine Verbindung mit der Basisstation aufzubauen.
Halten Sie die SYNC-Taste für 8 Sekunden gedrückt, um die Kamera zurückzusetzen.

Installing Battery

DE

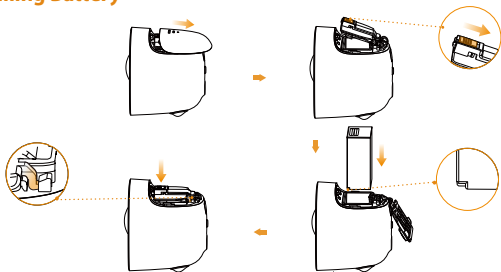

Das Muster der LED-Anzeigen ist in der folgenden Tabelle aufgeführt.

Anzeigestatus	Gerätestatus
Aus	<ul style="list-style-type: none">● Standby-Modus● Akku niedrig
Grüne LED leuchtet	<ul style="list-style-type: none">● Alarm ist ausgelöst● Standby-Modus wird verlassen
Grüne LED blinkt	<ul style="list-style-type: none">● Erneute Verbindung mit WLAN
Grüne LED blinkt schnell	<ul style="list-style-type: none">● Warten auf Kopplung mit Basisstation
Grüne LED leuchtet 10 Sekunden und erlischt dann	<ul style="list-style-type: none">● Kopplung erfolgreich
Rote LED leuchtet 10 Sekunden und erlischt dann	<ul style="list-style-type: none">● Zeitüberschreitung bei Kopplung
Rote LED leuchtet 1 Sekunden und erlischt dann	<ul style="list-style-type: none">● Zurücksetzen beendet

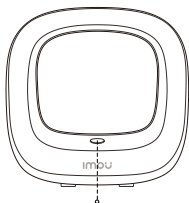

Synchronisationstaste

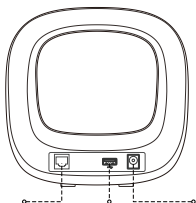

Ethernet-Anschluss

USB-Anschluss

Stromanschluss

1

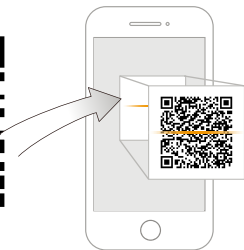

Imou Life



i Tips

DE

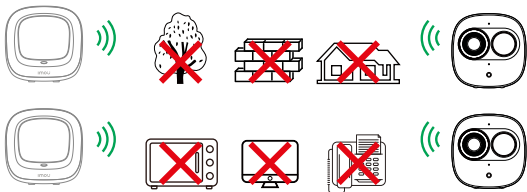

Um die bestmögliche Funkübertragung zu gewährleisten, stellen Sie sicher, dass zwischen Kamera und Hub keine Hindernisse und elektromagnetische Störungen vorhanden sind.

2

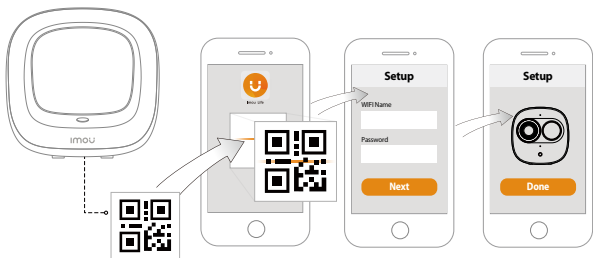

3 Pairing mit dem Hub

DE

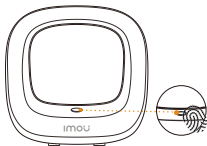

- 1 Drücken Sie die SYNC-Taste, die Anzeige auf der Basisstation blinkt weiß.

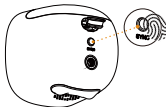

- 2 Drücken Sie die SYNC-Taste, die Anzeige auf der Kamera blinkt grün.

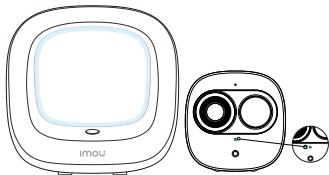

- 3
- Die Systemanzeige auf der Basisstation leuchtet für 10 Sekunden weiß und erlischt dann wieder.
 - Die Anzeige auf der Kamera leuchtet für 10 Sekunden grün und erlischt dann wieder. Die Kopplung wird erfolgreich.

Hinweis: Sie können maximal sechs Kameras, jeweils einzeln nacheinander, mit einer Basisstation koppeln.

Halten Sie während der Kopplung einen Abstand zwischen Basisstation und Kamera von maximal 30 cm ein.

Kamerainstallieren

DE

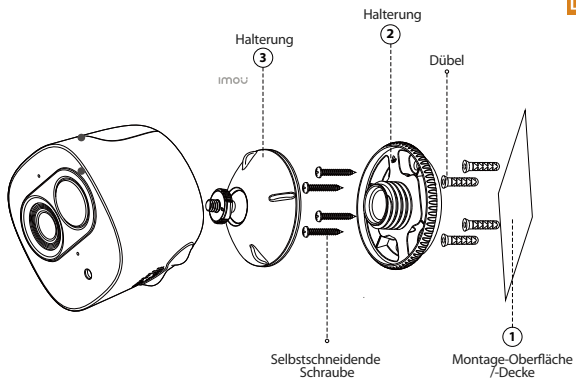

Fehlerbehebung

DE

Problem	Lösungen
Kamera kann nicht eingerichtet werden	<ul style="list-style-type: none">• Stellen Sie sicher, dass Ihr mobiles Gerät und die Kamera in Reichweite Ihres WLAN-Routers sind.• Vergewissern Sie sich, dass die LED-Anzeige an der Kamera grün blinkt, bevor Sie mit der Einrichtung beginnen.
Die App meldet: „Konfiguration des Gerätnetzes fehlgeschlagen“	<ul style="list-style-type: none">• Setzen Sie Ihre Kamera zurück und schließen Sie sie wieder an.• Einige Kameras unterstützen nur 2,4 GHz, während einige Router über Dualband mit 2,4 GHz/5 GHz verfügen. Stellen Sie sicher, dass Sie sie nur mit 2,4 GHz verbinden.
Die App meldet: „Verbindung fehlgeschlagen“	<p>Die Kamera ist bereits mit WLAN verbunden, aber der Router:</p> <ul style="list-style-type: none">• ist nicht mit dem Internet verbunden• hat einen mangelhaften Netzwerkzustand• Das WLAN-Signal ist aufgrund von Hindernissen oder elektronischen Störungen nicht stabil
Kein Bild/Signal	<ul style="list-style-type: none">• Stellen Sie sicher, dass die LED-Anzeige an der Kamera stetig grün blinkt. Siehe Abschnitt „LED-Status“ für Einzelheiten, wenn dies nicht der Fall ist.• Stellen Sie sicher, dass die Kamera mit dem mitgelieferten USB-Netzteil ordnungsgemäß an die Stromversorgung angeschlossen ist.• Versuchen Sie, die Kamera, den Router oder beides neu zu positionieren, um die Signalstärke zu verbessern.
Das Bild ist nicht klar	<ul style="list-style-type: none">• Überprüfen Sie das Kameraobjektiv auf Schmutz, Staub und Spinnennetze. Reinigen Sie das Objektiv mit einem weichen, sauberen Tuch.• Entfernen Sie die Kunststoff-Abdeckung des Kameraobjektivs.
Kein Ton	<ul style="list-style-type: none">• Stellen Sie sicher, dass der Kameraton eingeschaltet ist.• Stellen Sie sicher, dass der Ton am Anzeigergerät eingeschaltet ist.
Telefon liest keinen QR-Code	<ul style="list-style-type: none">• Reinigen Sie die Kamera in Ihre Smartphones• Stellen Sie sicher, dass der QR-Code ausreichend beleuchtet ist• Halten Sie den QR-Code nicht zu nah an die Kamera

Guía de inicio rápido

*Cell Pro(Add-on Camera)

*Cell Pro Kit(Hub+Camera)

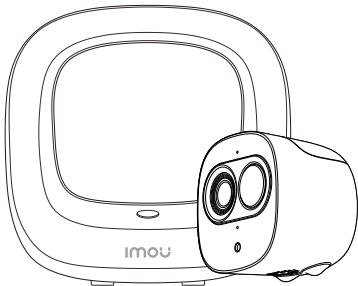

Bienvenido

ES

Gracias por elegir IMOU

Nuestra misión es proporcionar productos fáciles de usar para un hogar inteligente. Si tiene problemas usando el producto, por favor diríjase a nuestro equipo de atención al cliente antes de devolver su producto.

Nuestro correo electrónico de servicio:
service.global@imoulife.com

Nos comprometemos a contestarle en 24 horas.

Puede encontrar respuesta a las preguntas más frecuentes en imoulife.com/support/help



Contenido del paquete



Cámara x1



soporte x1



juego de tornillos x 1



Guía de inicio rápido x1



Plantilla de posicionamiento x1



batería x1



Adaptador de corriente x1



Cable de alimentación x1



Hub x1

ES

Introducción a la cámara

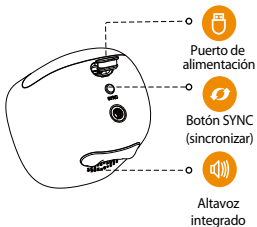
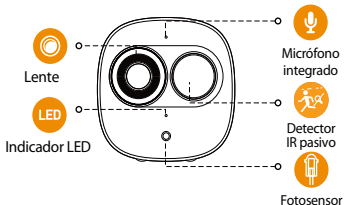

Nota: Pulse el botón SYNC (sincronizar) para emparejar con la estación base. Mantenga pulsado el botón SYNC durante 8 s para restablecer la cámara.

Instalar la batería

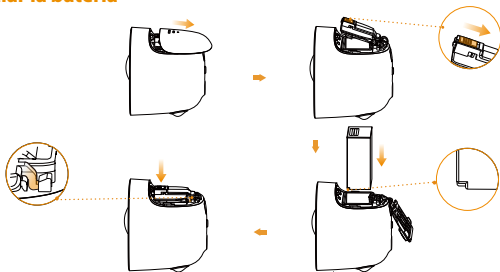

ES

El patrón de los indicadores LED se incluye en la siguiente tabla.

Estado LED	Estado del aparato
Desactivar	<ul style="list-style-type: none">● Modo de suspensión● Batería descargada
Luz verde encendida	<ul style="list-style-type: none">● La alarma se ha disparado● Se recibió orden de despertar
Luz verde parpadeante	<ul style="list-style-type: none">● Volviéndose a conectar a la red wifi
Luz verde parpadeante rápida	<ul style="list-style-type: none">● En espera para emparejarse con la estación base
La luz verde permanece encendida durante 10 s para, luego, apagarse	<ul style="list-style-type: none">● Emparejamiento realizado
La luz roja permanece encendida durante 10 s para, luego, apagarse	<ul style="list-style-type: none">● Tiempo de espera de emparejamiento
La luz roja permanece encendida durante 1 s para, luego, apagarse	<ul style="list-style-type: none">● Restablecimiento completado

Hub

ES

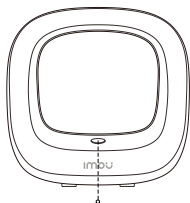

Botón SYNC
(sincronizar)

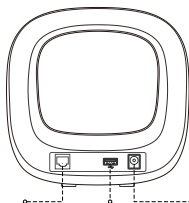

Puerto Ethernet Puerto USB Puerto de
alimentación

1

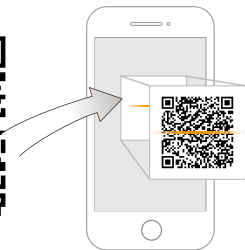

Imou Life



Download on the
App Store



GET IT ON
Google play



Windows

i Tips

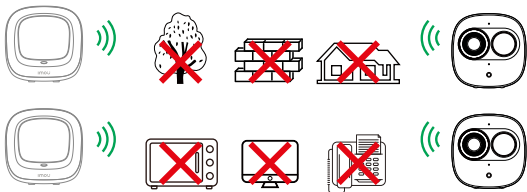

ES

Para garantizar el mejor rendimiento inalámbrico posible, por favor asegúrese de que no hay obstáculos ni interferencias electromagnéticas entre la cámara y el hub.

2

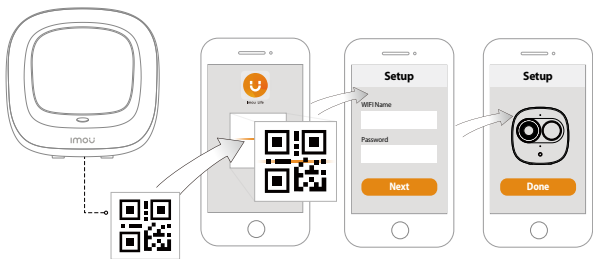

3 Emparejamiento con el Hub

ES

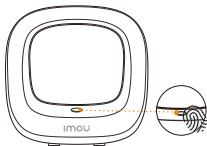

- 1 Pulse el botón SYNC y la luz blanca del indicador de la estación base parpadeará.

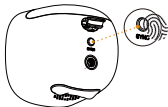

- 2 En la cámara Pulse el botón SYNC y la luz verde del indicador de la cámara base parpadeará.

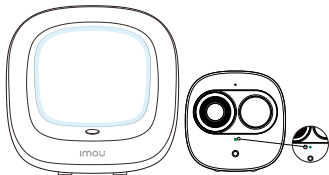

- 3
- La luz blanca del indicador del sistema de la estación base se mantiene encendida durante 10 s para, luego, apagarse.
 - La luz verde del indicador de la cámara se mantiene encendida durante 10 s para, luego, apagarse. Tras lo anterior, el emparejamiento es efectivo.

Nota: Es posible emparejar seis cámaras—como máximo—con una estación base, emparejándolas de una en una.

Mantenga una distancia no superior a los 30 cm (12 in) entre la estación base y la cámara durante el emparejamiento.

Instalación de la cámara

ES

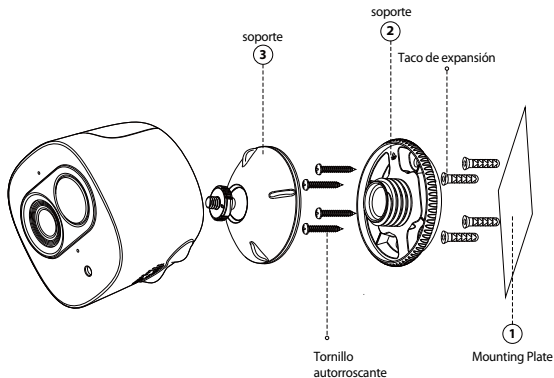

Solución de problemas

ES

Problema	Solución
No se puede configurar la cámara	<ul style="list-style-type: none">• Compruebe que su aparato móvil y la cámara están dentro del alcance de su router wifi.• Compruebe que el indicador LED de la cámara parpadea en color verde antes de comenzar la configuración.
La aplicación indica «Fallo al configurar la red del dispositivo»	<ul style="list-style-type: none">• Reinicie su cámara y conéctela de nuevo.• Algunas cámaras solo soportan 2,4 GHz, mientras que algunos routers tienen banda dual, 2,4G/5G. Compruebe que solo conecta a 2,4 GHz.
La aplicación indica «fallo al vincular»	<p>La cámara ya está conectada al wifi, pero el enrutador está:</p> <ul style="list-style-type: none">• Desconectado de Internet• Estado de la red deficiente• La señal de wifi no es estable debido a obstáculos o interferencia electrónica
Sin imagen / señal	<ul style="list-style-type: none">• Compruebe que el indicador LED de la cámara está encendido permanentemente en verde. De lo contrario, consulte la sección «Estado del LED» para conocer los detalles.• Compruebe que la cámara está adecuadamente conectada a la alimentación, usando el adaptador de corriente incluido.• Intente volver a ubicar la cámara, enrutador o ambos para mejorar la potencia de la señal.
La imagen no es clara	<ul style="list-style-type: none">• Verifique que la cámara no esté sucia, ni tenga polvo ni telarañas. Limpie la lente con un paño suave y limpio.• Retire la cubierta de vinilo de la lente de la cámara.
No hay sonido	<ul style="list-style-type: none">• Compruebe que la función de sonido de la cámara esté encendida.• Compruebe que el sonido en el dispositivo de visualización esté alto.
El teléfono no lee el código QR	<ul style="list-style-type: none">• Limpie la lente de la cámara en su teléfono móvil• Compruebe que el código QR recibe suficiente luz• No mantenga el código QR demasiado cerca de la cámara

Guide de démarrage rapide

*Cell Pro(Add-on Camera)

*Cell Pro Kit(Hub+Camera)

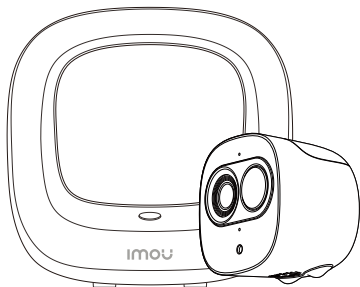

Bienvenue

FR

Merci d'avoir choisi IMOU.

Nous nous consacrons à fournir des produits pour la maison intelligente plus faciles à utiliser. Si vous rencontrez des difficultés lors de l'utilisation du produit, veuillez contacter notre équipe technique avant de renvoyer votre produit.

Notre courriel de service : service.global@imoulife.com

Nous nous engageons à vous répondre dans les 24 heures.

Les questions les plus fréquemment posées peuvent être consultées sur le site imoulife.com/support/help

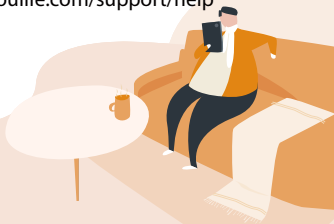

Contenu de l'emballage



Caméra x1



Guide de démarrage rapide x1



Adaptateur secteur x1



Support de montage x1



Patron d'installation x1



Cable de alimentación x1



jeu de vis x 1



Batterie x1



Le hub x1

FR

Introduction à la caméra

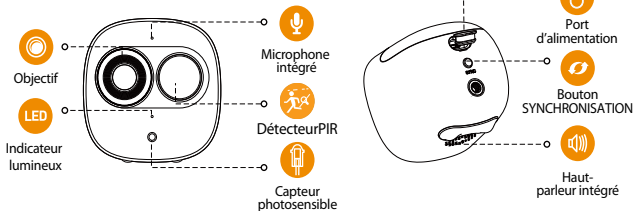

Remarque: Appuyez sur le bouton SYNCHRONISATION pour coupler l'appareil à sa station de base.

Maintenez enfoncé le bouton SYNCHRONISATION pendant 8s pour réinitialiser l'appareil.

Installation de la batterie

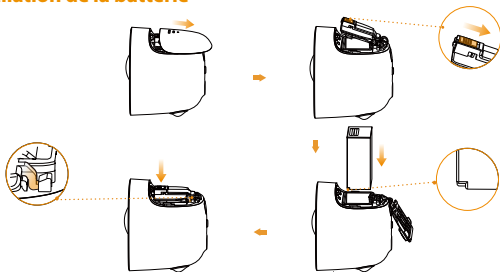

FR

Le schéma des voyants est inclus dans le tableau suivant.

Statut du voyant	État de l'appareil
Arrêt	<ul style="list-style-type: none">● Mode Sommeil● Batterie faible
Allumé en vert	<ul style="list-style-type: none">● Alarme déclenchée● Commande de réveil
Clignotant en vert	<ul style="list-style-type: none">● Reconnexion au Wi-Fi
Clignotement vert rapide	<ul style="list-style-type: none">● En attente de couplage avec la station de base
Indicateur lumineux vert s'allume pendant 10s, puis s'éteint	<ul style="list-style-type: none">● Couplage réussi
Indicateur lumineux rouge s'allume pendant 10s, puis s'éteint	<ul style="list-style-type: none">● Temporisation du couplage
Indicateur lumineux rouges'allume pendant 1s, puis s'éteint	<ul style="list-style-type: none">● Réinitialisation réussie

Le hub

FR

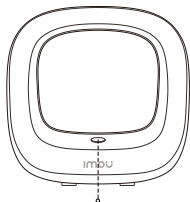

Bouton
SYNCHRONISATION

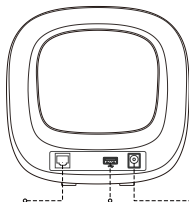

Port Ethernet Port USB Port
d'alimentation

1

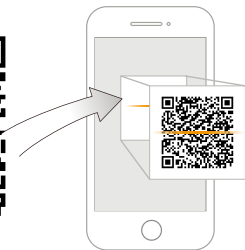

Imou Life



Download on the
App Store



GET IT ON
Google play



Windows

i Tips

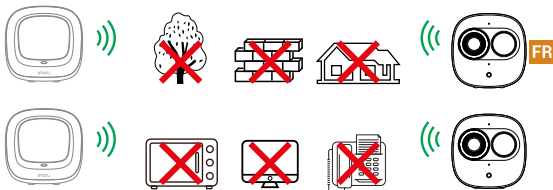

Pour garantir les meilleures performances sans fil possible, veuillez vous assurer qu'il n'y a pas d'obstacles ni d'interférences électromagnétiques entre la caméra et le hub.

2

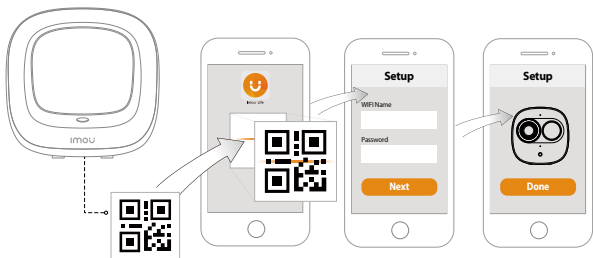

3 Couplage avec le hub

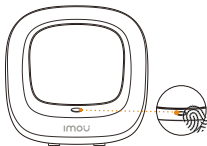

- 1 sur la station de base-Appuyez sur le bouton SYNC; l'indicateur lumineux de la station de base clignote en blanc.

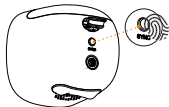

FR

- 2 sur la caméra-Appuyez sur le bouton SYNC; l'indicateur lumineux de la caméra clignote en vert.

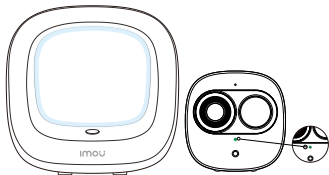

- 3
- L'indicateur lumineux système de la station de base s'allume en continu en blanc pendant 10s, puis s'éteint.
 - L'indicateur lumineux de la caméra s'allume en continu en vert pendant 10s, puis s'éteint. Le couplage est réussi.

Remarque: Vous pouvez coupler au plus six caméras à une station de base. Pour ce faire, coupez une caméra à la fois.

Mantenga una distancia no superior a los 30 cm (12 in) entre la estación base y la cámara durante el emparejamiento.

Installation de la caméra

FR

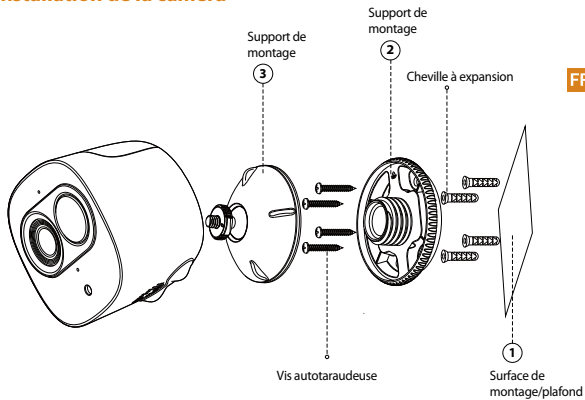

Dépannage

Problème	Solution
Impossible d'installer une caméra	<ul style="list-style-type: none">• Assurez-vous que votre appareil mobile et la caméra sont à portée de votre routeur Wi-Fi.• Assurez-vous que le voyant de la caméra clignote en vert avant de commencer la configuration.
L'APP indique « Échec de la configuration du réseau de l'appareil »	<ul style="list-style-type: none">• Réinitialisez votre caméra et rebranchez-la.• Certaines caméras ne prennent en charge que la bande 2,4 GHz, tandis que certains routeurs ont une double bande, 2,4 GHz/5 GHz. Assurez-vous de ne vous connecter que sur la bande 2,4 GHz.
L'application indique « Échec de la liaison »	La caméra est déjà connectée au Wi-Fi, mais le routeur est : <ul style="list-style-type: none">• Non connecté à Internet• Mauvais état du réseau• Le signal Wi-Fi n'est pas stable en raison d'obstacles ou d'interférences électroniques.
Pas d'image/de signal	<ul style="list-style-type: none">• Assurez-vous que le voyant de la caméra clignote en vert de façon continue. Voir la section « État du voyant » pour plus de détails, le cas échéant.• Assurez-vous que la caméra est correctement connectée à l'alimentation en utilisant l'adaptateur d'alimentation USB prévu à cet effet.• Essayez de repositionner la caméra, le routeur ou les deux pour améliorer la puissance du signal.
L'image n'est pas claire	<ul style="list-style-type: none">• Vérifiez que l'objectif de la caméra ne contient pas de saleté, de poussière ou de toiles d'araignées. Nettoyez la lentille à l'aide d'un chiffon doux et propre.• Retirez le couvercle en vinyle de l'objectif de la caméra.
Pas de son	<ul style="list-style-type: none">• Assurez-vous que la fonction audio de la caméra est activée.• Assurez-vous que le son est allumé sur l'appareil de visualisation.
Le téléphone ne lit pas le code QR	<ul style="list-style-type: none">• Nettoyez l'objectif de la caméra de votre smartphone• Veillez à ce que le code QR soit suffisamment clair• Ne tenez pas le code QR trop près de la caméra



Guida Rapida

*Cell Pro(Add-on Camera)

*Cell Pro Kit(Hub+Camera)

IT

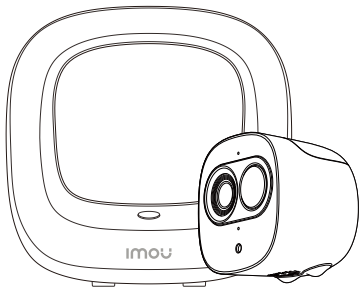

Benvenuti

IT

Grazie per aver scelto IMOU.

Il nostro obiettivo è quello di fornire prodotti per la domotica più facili da utilizzare. In caso di problemi durante l'utilizzo del prodotto, si prega di contattare il nostro team di assistenza prima di restituire il prodotto.

La nostra e-mail per il servizio di assistenza:

service.global@imoulife.com

Promettiamo di rispondere entro 24 ore.

Le risposte alle domande più frequenti sono disponibili all'indirizzo imoulife.com/support/help

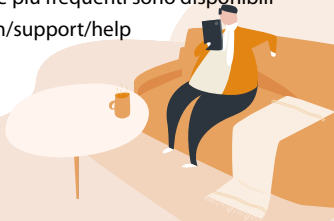

Contenuto della confezione



Telecamera x1



Guida
introduttiva x1



Adattatore x1



Supporto x1



Dima di
posizionamento x1



Cavo di
alimentazione x1



confezione di viti x 1



Batteria x1



Hub x1

IT

Introduzione alla telecamera

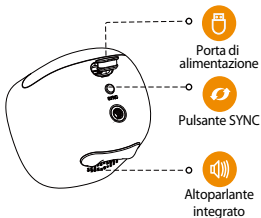
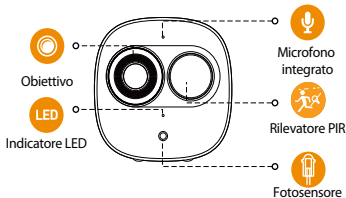

Nota: Premere il pulsante SYNC per associarla alla stazione di base.
Premere e tenere premuto il pulsante SYNC per 8 secondi per reimpostare la telecamera.

Installazione della batteria

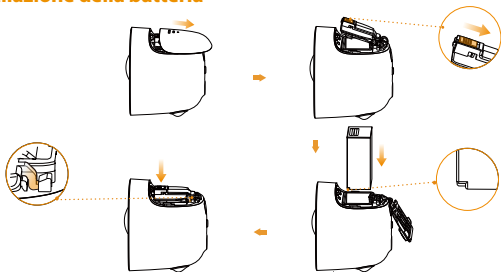

IT

Gli indicatori LED sono descritti nella tabella seguente.

Stato LED	Stato dispositivo
SPENTO	<ul style="list-style-type: none">● Modalità notturna● Batteria scarica
Luce verde accesa	<ul style="list-style-type: none">● Allarme attivato● Impostazione di attivazione
Luce verde lampeggiante	<ul style="list-style-type: none">● Riconnesione alla rete Wi-Fi
Indicatore verde che lampeggia rapidamente	<ul style="list-style-type: none">● In attesa di associazione con la stazione base
Spia verde accesa per 10 secondi, quindi spenta	<ul style="list-style-type: none">● Associazione completata
Spia rossa accesa per 10 secondi, quindi spenta	<ul style="list-style-type: none">● Timeout associazione
Spia rossa accesa per 1 secondo, quindi spenta	<ul style="list-style-type: none">● Reimpostazione completata

Hub

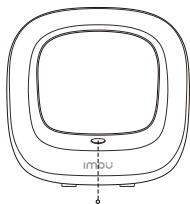

Pulsante SYNC

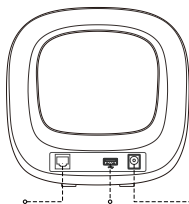

Porta Ethernet

Porta USB

Porta di
alimentazione

IT

1

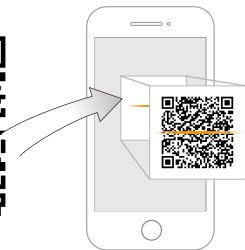

Imou Life



i Tips

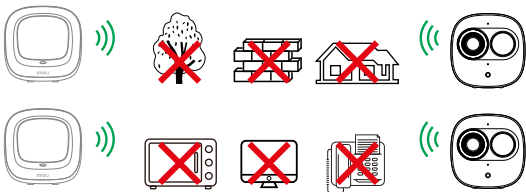

Per garantire le migliori prestazioni wireless possibili, assicurarsi che non ci siano ostacoli e interferenze elettromagnetiche tra la telecamera e il hub.

2

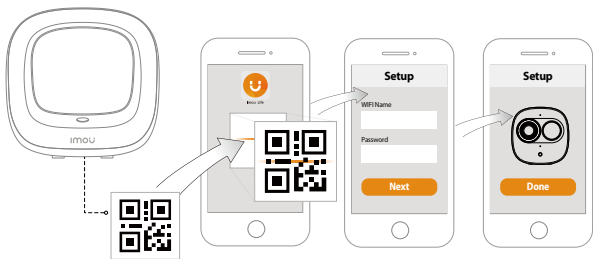

3 Associazione con l'hub

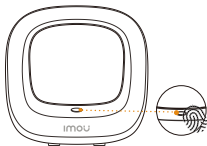

- 1 premere il pulsante SYNC, quindi l'indicatore della stazione di base lampeggia con spia bianca.

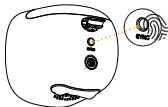

IT

- 2 premere il pulsante SYNC, quindi l'indicatore della telecamera lampeggia con spia verde.

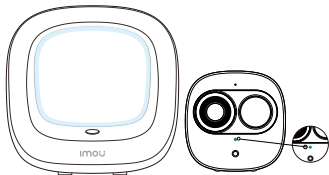

- 3
- L'indicatore sulla stazione di base resta acceso con spia bianca per 10 secondi, quindi si spegne.
 - L'indicatore sulla telecamera resta acceso con spia verde per 10 secondi, quindi si spegne. L'associazione è stata quindi completata.

Nota: È possibile associare un massimo di sei telecamere per stazione di base e una telecamera alla volta.

Mantenere la distanza tra la stazione di base e la telecamera entro 30 cm (12 pollici) durante l'associazione.

Installazione della telecamera

IT

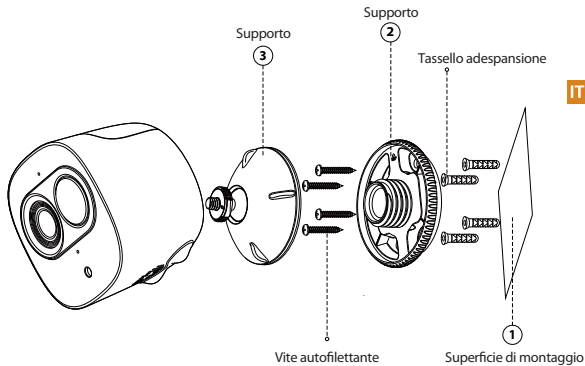

Risoluzione dei problemi

Problema	Soluzione
Impossibile impostare la telecamera	<ul style="list-style-type: none">• Assicurarsi che il dispositivo mobile e la telecamera si trovino nel raggio d'azione del router Wi-Fi.• Assicurarsi che l'indicatore LED della telecamera lampeggi con luce verde prima di cominciare l'impostazione.
L'app mostra il messaggio "Impossibile configurare la rete del dispositivo"	<ul style="list-style-type: none">• Resetare la telecamera e collegarla di nuovo.• Alcune telecamere supportano solo la frequenza 2,4 GHz, mentre alcuni router sono a doppia banda (2,4/5 GHz). Accertarsi di utilizzare solo la connessione da 2,4 GHz.
L'app mostra la notifica "Associazione non riuscita"	La telecamera è già connessa alla rete Wi-Fi, ma il router: <ul style="list-style-type: none">• Non è connesso a Internet• Ha una scarsa qualità del segnale di rete• Il segnale Wi-Fi non è stabile a causa di ostacoli e interferenze elettroniche
Assenza di immagine/segnale	<ul style="list-style-type: none">• Assicurarsi che l'indicatore LED della telecamera lampeggi con luce verde. In caso contrario, fare riferimento alla sezione "Stato LED" per maggiori dettagli.• Assicurarsi che la telecamera sia correttamente connessa alla fonte di alimentazione tramite l'alimentatore USB.• Provare a modificare la posizione della telecamera o del router o di entrambi i dispositivi per migliorare la potenza del segnale.
L'immagine non è chiara	<ul style="list-style-type: none">• Controllare che l'obiettivo della fotocamera sia libero da sporco, polvere o ragnatele. Pulire l'obiettivo con un panno morbido inumidito.• Rimuovere il coperchio in vinile dall'obiettivo della telecamera.
Non c'è suono	<ul style="list-style-type: none">• Accertarsi che la funzione audio della telecamera sia attiva.• Accertarsi che l'audio del dispositivo ricevente sia acceso.
Il telefono non legge il codice QR	<ul style="list-style-type: none">• Pulire l'obiettivo della fotocamera dello smartphone• Accertarsi che il codice QR sia ben illuminato• Non tenere il codice QR troppo vicino alla fotocamera dello smartphone

Snelstartgids

*Cell Pro(Add-on Camera)

*Cell Pro Kit(Hub+Camera)

NL

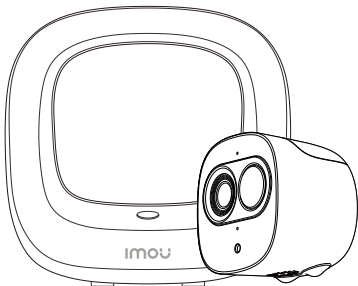

Welkom

Bedankt dat u voor Imou heeft gekozen.

NL

Onze toewijding is om u eenvoudige Smart Home producten te bieden. Als u problemen ervaart met het gebruik van uw product, neem dan eerst contact op met onze service team: service.global@imoulife.com



Inhoud verpakking



Camera x1



Snelstarhandleiding
x1



Voedingsadapter x1



Beugel x1



Kaart
installatiepositie x1



Netsnoer x1



Schroefpakket x1



Batterij x1



Hub x1

NL

Introductie camera

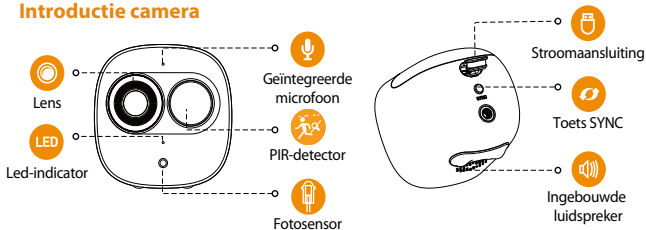

Opmerking: Druk op de toets SYNC om met het basisstation te koppelen. Houd de toets SYNC gedurende 8seconden ingedrukt om de camera te herstellen.

Batterij installeren

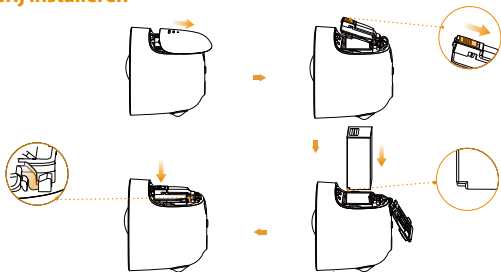

NL

Het patroon van led-indicatoren wordt weergegeven in de volgende tabel.

LED-IndicatorStatus	Status apparaat
Uit	<ul style="list-style-type: none">● Slaapmodus● Batterij is leeg
Groen lampje aan	<ul style="list-style-type: none">● Alarm wordt geactiveerd● Opgedragen om te wekken
Groen lampje knippert	<ul style="list-style-type: none">● Opnieuw verbinden Wi-Fi
Snel knipperend groen lampje	<ul style="list-style-type: none">● Wachten op koppelen met het basisstation
Het groenlampje blijft 10 sec. branden en gaat dan uit	<ul style="list-style-type: none">● Koppelen gelukt
Het rode lampje blijft 10 sec. branden en gaat dan uit	<ul style="list-style-type: none">● Onderbreking koppelen
Het rode lampje blijft 1 sec. branden en gaat dan uit	<ul style="list-style-type: none">● Herstellen voltooid

Hub

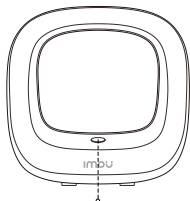

Toets SYNC

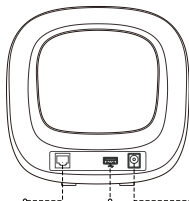

Ethernetpoort

USB poort

Stroomaansluiting

NL

1

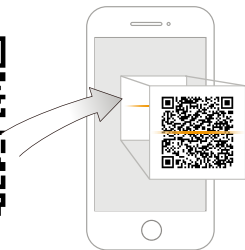

Imou Life



i Tips

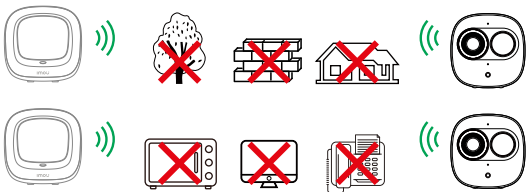

NL

Zorg voor de best mogelijke draadloze prestatie dat er geen obstakels en elektromagnetische interferentie tussen de camera en hub aanwezig zijn.

2

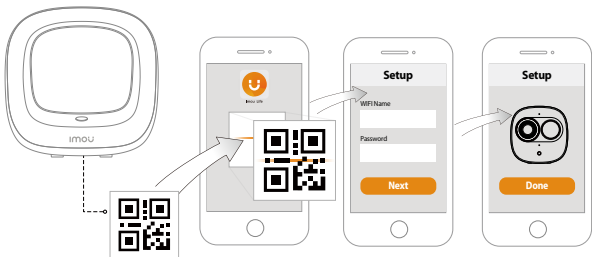

3 Couplage avec le hub

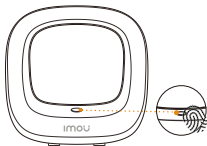

- 1 Druk op de toets SYNC, waarna het indicatielampje ophet basisstation wit gaat knipperen.



- 2 Druk op de toets SYNC, waarna het indicatielampje opdecamera groen gaat knipperen.

NL

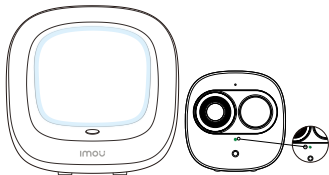

- 3
- De systeemindicator op het basisstation blijft gedurende 10 sec. wit branden en gaat dan uit.
 - Het indicatielampje op de camera blijft gedurende 10 sec. groen branden en gaat dan uit. Dan is het koppelen gelukt.

Opmerking: U kunt maximaal zes camera's met één basisstation koppelen en één camerategelijk koppelen.

Houd tijdens het koppelen een afstand van 30 cm (12 inch) aan tussen het basisstation en de camera.

Het installeren van de camera

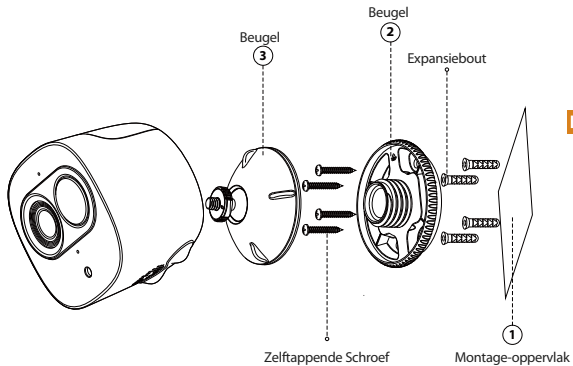

NL



Probleemoplossing

Probleem	Oplossing
Kan de camera niet instellen	<ul style="list-style-type: none">• Zorg ervoor dat uw mobiele apparaat en de camera zich binnen het bereik van uw wifi-router bevinden.• Zorg ervoor dat de led-indicator op de camera groen knippert voordat u met de installatie begint.
De app zegt "Instellen apparaatnetwerk mislukt"	<ul style="list-style-type: none">• Reset uw camera en verbind deze opnieuw.• Sommige camera's ondersteunen enkel 2,4 GHz, terwijl sommige routers een dubbele band hebben, namelijk 2,4 GHz en 5 GHz. Zorg ervoor dat u alleen verbinding maakt met de 2,4 GHz band.
De app zegt "Verbinding mislukt"	De camera is al verbonden met wifi, maar: <ul style="list-style-type: none">• De router is niet verbonden met het internet• De router heeft een slechte netwerkstatus• Het wifi-signaal van de router is niet stabiel vanwege obstakels of elektronische interferentie
Geen beeld/signaal	<ul style="list-style-type: none">• Zorg ervoor dat de led-indicator op de camera groen knippert. Zie de sectie "ledstatus" voor details indien dit niet het geval is.• Zorg ervoor dat de camera voorzien is van stroom door gebruik te maken van de meegeleverde USB-spanningsadapter.• Probeer de camera, router of beide te verplaatsen om de signaalsterkte te verbeteren.
Beeld is niet duidelijk	<ul style="list-style-type: none">• Controleer de cameralens op vuil, stof en spinnenwebben. Reinig de lens met een zachte, schone doek.• Verwijder het vinyldeksel op de cameralens.
Geen audio	<ul style="list-style-type: none">• Zorg ervoor dat de audiofunctie op de camera is ingeschakeld.• Zorg ervoor dat audio wordt ingeschakeld op het kijkapparaat.
Telefoon leest geen QR-code	<ul style="list-style-type: none">• Reinig de cameralens van uw telefoon• Zorg ervoor dat de QR-code voldoende belicht wordt• Houd de QR-code niet te dicht bij de camera



Guia rápido

*Cell Pro(Add-on Camera)

*Cell Pro Kit(Hub+Camera)

PT

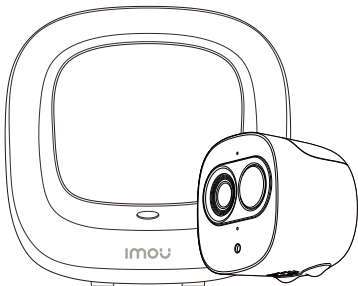

Bem-vindo

Obrigado por escolher a IMOU.

Estamos empenhados em fornecer produtos inteligentes e simplificados para o lar. Se tiver problemas ao utilizar o produto, contacte a nossa equipa de assistência antes de devolver o produto.

PT

O nosso e-mail de assistência: service.global@imoulife.com
Prometemos responder no prazo de 24 horas.

Pode encontrar as Perguntas frequentes em imoulife.com/support/help

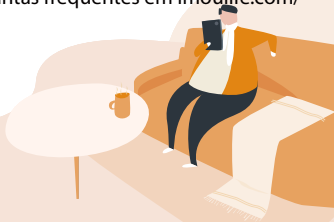

Conteúdo da embalagem



Câmara x 1



Suporte x1



Conjunto de parafusos x1



Guia de início rápido x1



Mapa de posicionamento x1



Bateria x1



Adaptador de energia x1



Cabo de alimentação x1



Hub x1

PT

Apresentação da câmara

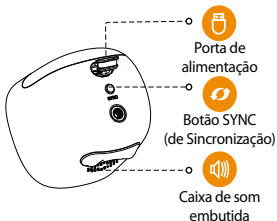
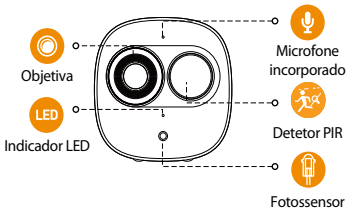

Nota: Prima o botão SYNC para emparelhar com a estação interior. Prima sem soltar o botão SYNC durante 8 segundos para repor as definições da câmara.

Instalar a Bateria

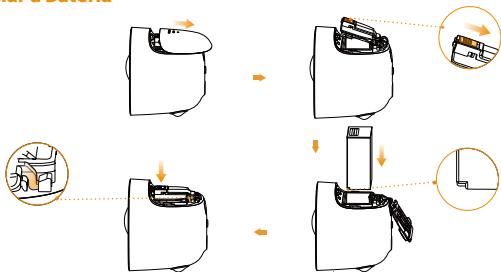

PT

O padrão dos indicadores LED está incluído na tabela seguinte.

Estado do LED	Estado do dispositivo
DESLIGADO	<ul style="list-style-type: none">● Modo de suspensão● Sem bateria
Luz verde acesa	<ul style="list-style-type: none">● Alarme ativado● Instruído a ligar
Luz verde intermitente	<ul style="list-style-type: none">● A ligar novamente o Wi-Fi● A aguardar o emparelhamento com a estação interior
Luz verde rapidamente intermitente	<ul style="list-style-type: none">● Emparelhamento bem-sucedido
A luz verde acende durante 10 segundos e depois apaga-se	<ul style="list-style-type: none">● Emparelhamento bem-sucedido
A luz vermelha acende durante 10 segundos e depois apaga-se	<ul style="list-style-type: none">● Tempo de emparelhamento esgotado
A luz vermelha acende durante 1 segundo e depois apaga-se	<ul style="list-style-type: none">● Reposição concluída

Hub

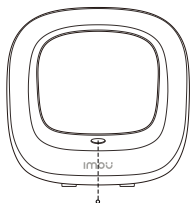

Botão SYNC
(de Sincronização)

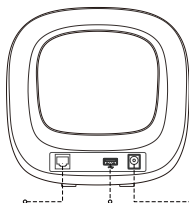

Entrada Ethernet

Porta USB

Porta de
alimentação

PT

1

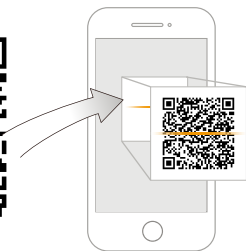

Imou Life



Download on the
App Store



GET IT ON
Google play



Windows

i Tips

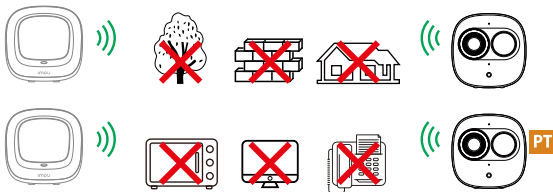

Para assegurar o melhor desempenho possível do sistema sem fios, certifique-se de que não existem obstáculos e interferência eletromagnética entre a câmara e o hub.

2

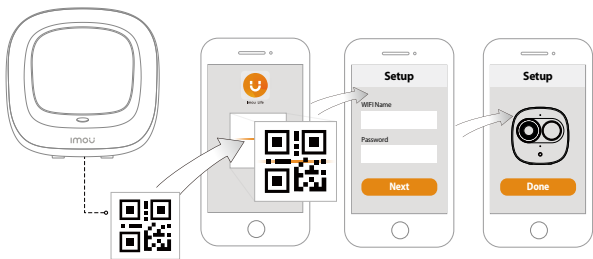

3 Emparelhando com o Hub

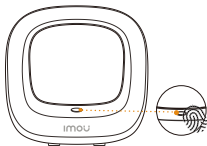

- 1 Prima o botão SYNC e o indicador na estação interior piscará a branco.



- 2 Prima o botão SYNC e o indicador na câmara piscará a verde.

PT

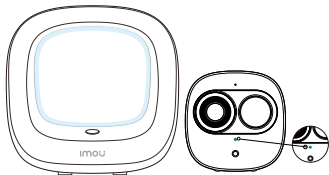

- 3
- O indicador do sistema na estação interior acende a branco durante 10 segundos e depois apaga-se.
 - O indicador na câmara acende a verde durante 10 segundos e depois apaga-se. O emparelhamento foi bem-sucedido.

Nota: Pode emparelhar no máximo seis câmaras com uma estação interior e emparelhar uma câmara de cada vez.

Mantenha a estação interior e a câmara a uma distância máxima de 30 cm (12 polegadas) durante o emparelhamento.

Instalar a câmara

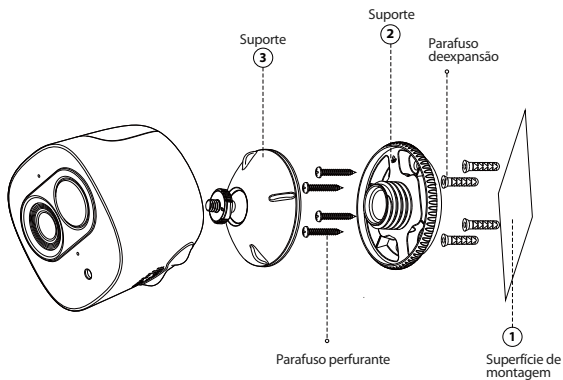

PT



Solução de problema

Problema	Solução
Não é possível configurar a câmara	<ul style="list-style-type: none">• Certifique-se de que o dispositivo móvel e a câmara estão dentro do alcance do router de Wi-Fi.• Certifique-se de que o indicador LED na câmara está verde intermitente antes da configuração.
A app informa "A configuração da rede do dispositivo falhou"	<ul style="list-style-type: none">• Reponha a câmara e ligue-a novamente.• Algumas câmaras suportam apenas 2,4 GHz, enquanto alguns routers possuem banda dupla, 2,4 G/5G. Certifique-se de que liga apenas a 2,4 GHz.
A app informa "A associação falhou"	A câmara já está ligada ao Wi-Fi, mas o router: <ul style="list-style-type: none">• Não está ligado à Internet• O estado da rede é fraco• O sinal Wi-Fi não é estável devido a obstáculos ou interferência eletrónica
Sem imagem/sinal	<ul style="list-style-type: none">• Certifique-se de que o indicador LED na câmara está verde fixo. Consulte a secção "Estado do LED" para obter detalhes, caso seja necessário.• Certifique-se de que a câmara está devidamente ligada com o adaptador de corrente USB.• Tente reposicionar a câmara, o router ou ambos para melhorar a força do sinal.
A imagem não está nítida	<ul style="list-style-type: none">• Verifique a objetiva da câmara para verificar a existência de sujidade, pó e teias de aranha. Limpe a objetiva com um pano limpo e macio.• Retire a tampa de vinil da objetiva da câmara.
Sem áudio	<ul style="list-style-type: none">• Certifique-se de que a função de áudio na câmara está ativada.• Certifique-se de que o áudio está ligado no dispositivo de visualização.
O telefone não consegue ler o código QR	<ul style="list-style-type: none">• Limpe a objetiva da câmara do smartphone• Certifique-se de que existe luminosidade suficiente no código QR• Não coloque o código QR demasiado perto da câmara

PT

imou

Enjoy Smart Life



CE FC CCC UL  ISO 9001:2000

 @imouglobal

 service.global@imoulife.com

 www.imoulife.com